

1023253008

EBMDR-8

Exigo Button Expansion Module, 8 Buttons



 AlphaCom

 Exigo

 EN54 EN54-16 Certified

 UL Certified Intercom

DESCRIPTION

- Button expansion module for Exigo console mounted access panels
- Powered from master access panel
- Eight programmable buttons with individual labels and status indicators
- Optional button protection covers
- Four units can be connected to one access panel

The EBMDR-8 button expansion module is developed for expanding the button capacity of Exigo console panels. Each button features eight fully programmable buttons that can be used to manually initiate alarms, select zones, or any other action in the Exigo system.

Each of the module's buttons features two independent indicators that show the status of the button's function. Up to four EBMDR-8 button expansion modules can be daisy chained to one console panel.

SPECIFICATIONS

MECHANICAL

Dimensions (HxWxD):	144 x 96 x 41.5 mm
Weight:	500 g
Storage temperature:	-40°C to +70°C
Storage humidity:	10% to 95% (non-condensing)
Air pressure:	600 hPa to 1300 hPa
IP rating:	IP-32

ENVIRONMENTAL

Operating temperature:	-10°C to +60 °C
Operating humidity:	10% to 95% (non-condensing)

CERTIFICATIONS

Immunity:	EN 60945, EN 50130-4, EN 61000-6-1, EN 61000-6-2, EN 55103-2, FCC-47 part 15B
Emissions:	EN 60945, EN 50130-4, EN 61000-6-3, EN 61000-6-4, EN 55103-1, FCC-47 part 15B
Safety:	UL 60950-1, cUL 60950-1, CB to IEC 60950-1

TECHNICAL DIMENSIONS

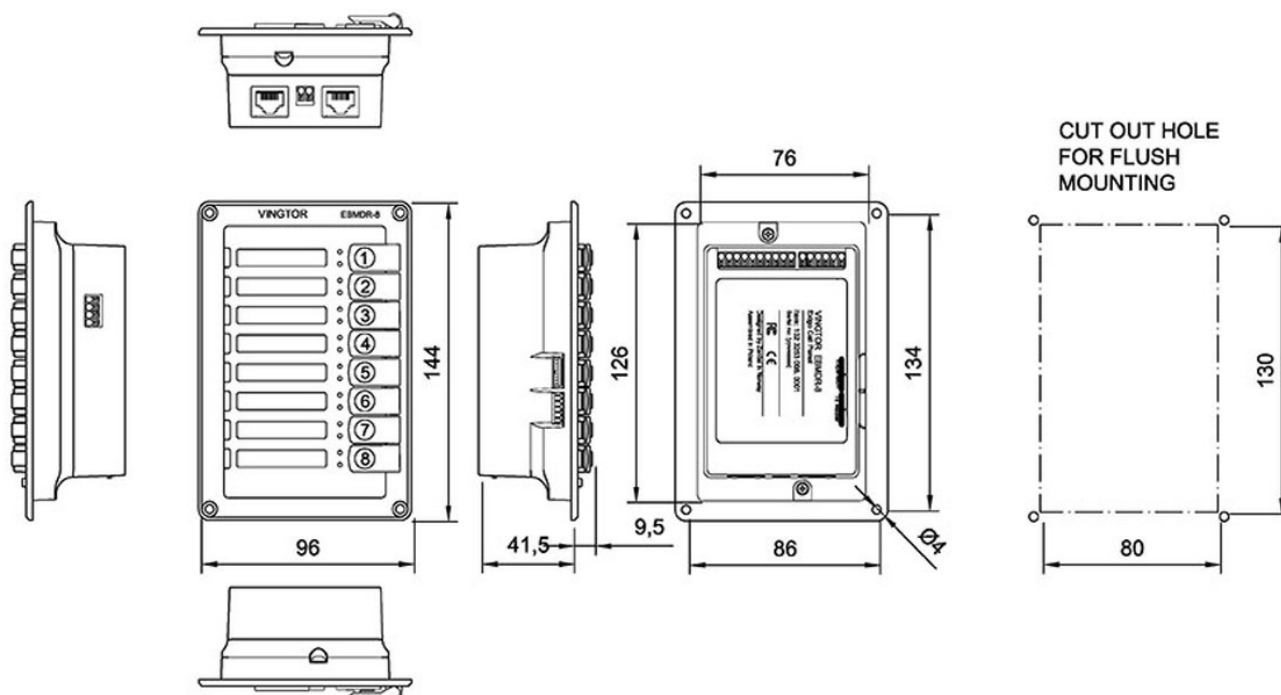

ACCESSORIES



EMBR-1

Item number: 1023595010



EMBR-2

Item number: 1023595020

USED WITH



1023200033

ECPIR-3P

Exigo Call Panel, PTT Button and 3 buttons



1023200030

ECPIR-P

Exigo Call Panel, PTT Button



1023201008

EAPIR-8

EXIGO Alarm Panel, 8 buttons